

Wabash

TECHNOLOGIES

RUGGED
VERSATILE
HIGH LIFE
LOW COST

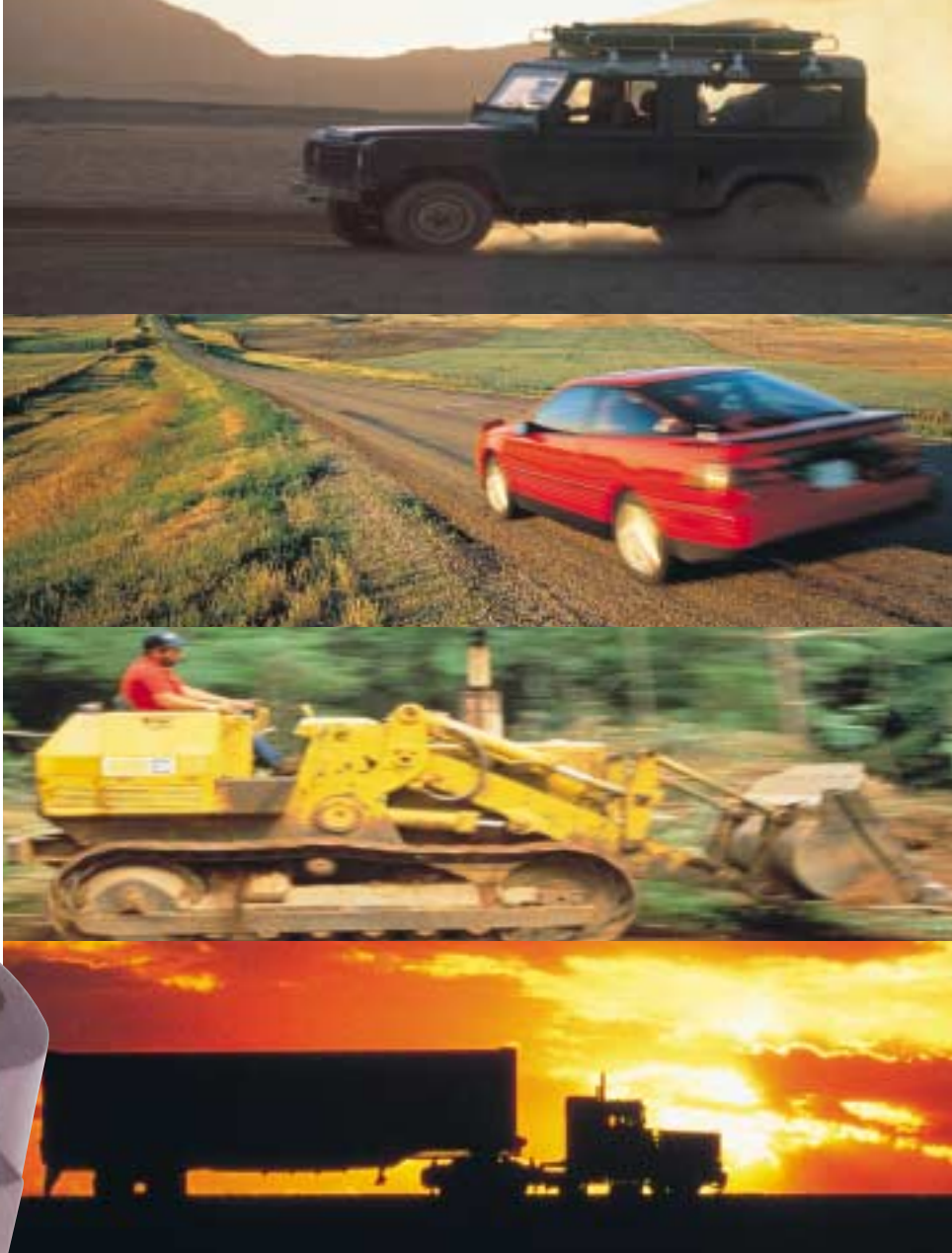

RPS-971-0002

RPS-971-0001



Reliable From Any ANGLE

The Wabash **RPS 971** Rotary Position Sensor

The Wabash RPS 971 has been specifically designed to operate in demanding environments where long life and high performance are required. Our dedication to continuous improvement has resulted in a product which now meets automotive standards - an industrial sensor with an automotive pedigree. The RPS 971 can withstand:

- Extremes of temperature
- Continuous vibration
- Mechanical shock handling

At Wabash, we fully understand the critical role that sensors play in the enhancement of sophisticated control systems. Our proven high performance conductive polymer tracks and contact design achieve 2% independent linearity, making the RPS 971 extremely

reliable in every application.

The product can be supplied with options for electrical track length, resistance, flying leads, integral connector and actuator drive direction.

Practical and highly versatile, typical applications for the RPS 971 include:

- Electrical industrial vehicles
- Off-road steering and transmission
- Automotive engine management systems & control
- Medical
- Agricultural

Wabash recognises the need to work in partnership with our customers to provide cost-effective custom and standard solutions to meet exacting system requirements.

As a QS9000 certified organisation, our commitment is to constantly exceed the expectations of our customers through the highest quality standards.

*Committed
to Sensor
Advancement*

Technical Specification



Physical:

- High performance, compact potentiometric sensor
- Suitable for arduous engine management and closed loop control system feedback applications
- Through-hole actuation capability
- Integral connector or flying lead versions
- Actuator and mounting configuration options

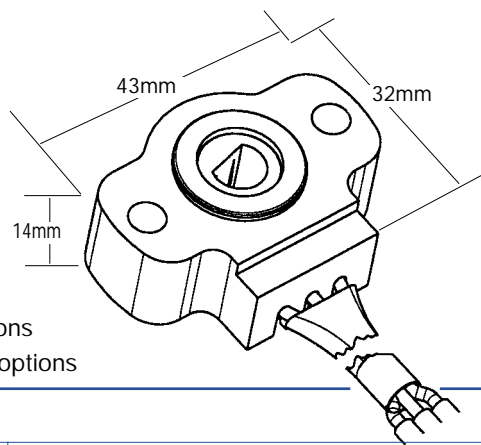

Electrical:

	Specification
Track Resistance (R _t)	5K Ω \pm 20% @ 20°C \pm 10°C
Linearity (Independent)	\pm 2%
Index Point	3% \pm 2% @ -Low End Stop
Output Gradient	0.973%/° Max 0.873%/° Min
Power Rating	1 Watt @ 40°C Derated to Zero @ 135°C
Temperature Coefficient	\pm 600ppm/°C
Insulation Resistance	1000M Ω Min 500V DC
Maximum Voltage	13.5V DC

Mechanical:

Rotation	128° \pm 2°
Spring Torque	Min Return - 6 Nmm Max Wind up - 120 Nmm
Mechanical End Stop Strength	680Nmm Min
Fixing Torque (M4 and Washer)	2Nm Maximum
Lead Wire version 971 - 0002	16/0.2, 0.5 mm CSA 1.8 mm OD Pull Strength: 10 kg Max (all 3 wires)
Connector Version 971 - 0001	Connector to M47/2 AMP P/N 828748 - 3

Performance & Environmental:

Rotation Life (-40° - +130°C)	5, 000, 000 Full Cycles 10, 800, 000 Dither Cycles (2°)
Functional Temperature Range	-40°C to +85°C Wire Version -40°C to +155°C Connector Version
Mechanical Shock (Handling)	1m Drop onto Concrete Floor
Mechanical Shock (Bump)	1000 40 g 11 ms Shocks (3 axis)
Vibration (Sinusoidal)	10 - 57 Hz @ 1 mm Displacement 57 - 100 Hz @ 10 g 100 - 500 Hz @ 27 g
Sealing	IP 5X (dust)
Pressure Wash	90 Bar 0.5-0.6 m 5-6 Seconds
Humidity	40°C 96% RH 504 Hours
Chemical Resistance	Screen Wash, Gearbox Oil Brake Fluid Dot 4 Isoctane/Toluene (70/30) + 15% Methanol Engine Cleaning Agent, Engine Coolant Antigel Fluid, Electrolyte Density 1285 Kg/m ³ (Sulphuric Acid H ₂ SO ₄)

Wabash Sensor Group Inc.
Automotive Business Unit
1375 Swan Street, P.O. Box 829, Huntington, IN 46750-0829, USA.
Phone: +1 219-356-8300 Fax: +1 219-356-3846

Wabash Sensor Group Ltd.
Automotive Business Unit
Unit 125, 5 Faraday Park, Dorcan, Swindon, Wiltshire, SN3 5JF, England.
Phone: +44 1793 600500 Fax: +44 1793 600600

Wabash Sensor Group Technical Center
46365 Five Mile Rd, Plymouth, MI 48170, USA.
Phone: +1 734 453 5145 Fax: +1 734 453 5859